

Wood Hood

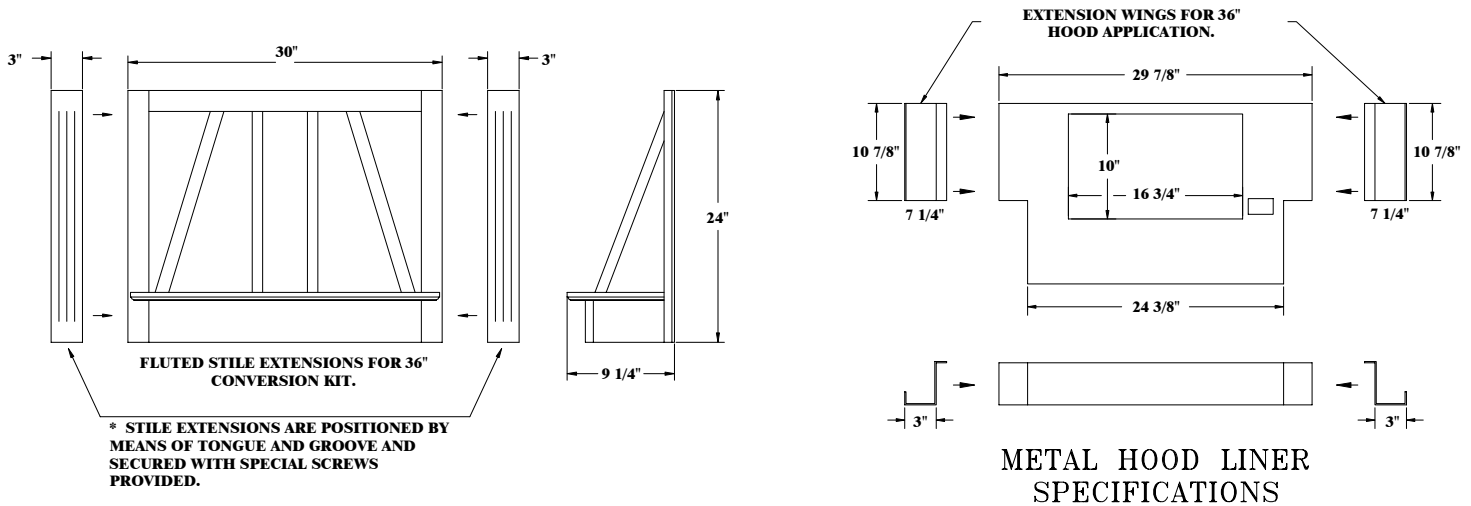

Part #	Description	Units/Carton	Weight/Carton
HOOD-30-RO	30" Wood Hood W/liner - Red Oak	1	28 lbs.
HOOD-30-HK	30" Wood Hood W/liner - Hickory	1	28 lbs.
HOOD-30-HM	30" Wood Hood W/liner - Hard Maple	1	28 lbs.
HOOD-30-CH	30" Wood Hood W/liner - Cherry	1	28 lbs.
CONKIT-36-RO	36" Wood Hood Conversion Kit - Red Oak	1 Pair	3 lbs.
CONKIT-36-HK	36" Wood Hood Conversion Kit - Hickory	1 Pair	3 lbs.
CONKIT-36-HM	36" Wood Hood Conversion Kit - Hard Maple	1 Pair	3 lbs.
CONKIT-36-CH	36" Wood Hood Conversion Kit - Cherry	1 Pair	3 lbs.

Application Features

- * All wood construction adds to the natural beauty of the kitchen.
- * Designed to be easily installed between two wall cabinets.
- * Can be stained to match other cabinets.

Product Features

- * Available in Red Oak, Hard Maple, Cherry, & Hickory.
- * Completely sanded and ready for finishing.
- * Optional English Country and spindle rail trim kits also available.
- * Conversion Kit includes 3" fluted stile extensions and metal extension wings for a 36" wide application.
- * Individually cartoned for easy re-shipment.

BLENDING TECHNOLOGY AND TRADITION

Hoffco, Inc.

QUALITY WOOD MANUFACTURING